



TR-3D SUBWOOFER

OWNER'S GUIDE



CONTENTS

- 4 IMPORTANT SAFETY INSTRUCTIONS
- 5 INTRODUCTION
- 6 ABOUT YOUR SUBWOOFER
- 7 PLACEMENT OF SUBWOOFER
- 8 CONTROLS AND CONNECTIONS
- 10 2.1 SET UP
- 11 MULTI-CHANNEL SET UP
- 12 SPECIFICATIONS AND WARNING
- 13 TECHNICAL SUPPORT AND WARRANTY

IMPORTANT SAFETY INSTRUCTIONS

All safety instructions should be read and followed before the product is operated.

WARNING

DO NOT OPEN OR REMOVE ANY COMPONENTS - DANGER OF ELECTRICAL SHOCK. THERE ARE NO USER SERVICEABLE PARTS INSIDE.

ALWAYS PROVIDE ADEQUATE VENTILATION AS THE UNIT MAY BECOME HOT DURING USE. DO NOT PLACE NEAR A HEAT SOURCE OR COVER.

FURTHER ADVICE

Do not use this product near water or moisture, or heat sources like radiators.

Only use the power cable supplied.

Route the power cable away from areas where it could be damaged or walked on.

Do not overload wall sockets or extension cords.

If there is any damage or failure, unplug the subwoofer from the wall socket immediately and consult qualified sources for advice.

In the event of a failure, contact your dealer, distributor or Gallo Acoustics directly to arrange repair.

PRODUCT DISPOSAL INSTRUCTIONS

(WEEE DIRECTIVE)

The symbol shown here means that it is classed as Electrical or Electronic Equipment and should not be disposed with other household or commercial waste at the end of its working life.

The Waste of Electrical and Electronic Equipment (WEEE) Directive (2002/96/EC) has been put in place to recycle products using best available recovery and recycling techniques to minimise the impact on the environment, treat any hazardous substances and avoid the increasing landfill.

For more information please contact your local authority or the retailer where the product was purchased.

INTRODUCTION

Thank you for choosing Gallo Acoustics.

Please take the time to read and understand this guide thoroughly before installing your subwoofer. This will ensure that you achieve optimal performance without the risk of causing damage to your subwoofer, speakers or amplifier.

RUN-IN PERIOD

Your Gallo Acoustics subwoofer utilises proprietary technologies that only reach their optimum performance levels after a period of 60 - 80 hours of use. During this run-in process the loudspeaker driver will loosen-up, the patented S2 fill material will settle, and your loudspeakers will develop the acoustic characteristics that are our signature.

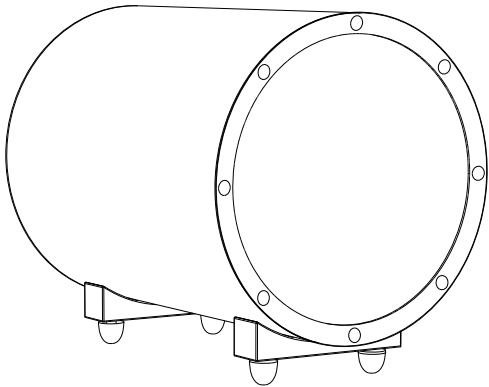

TR-3D FRONT

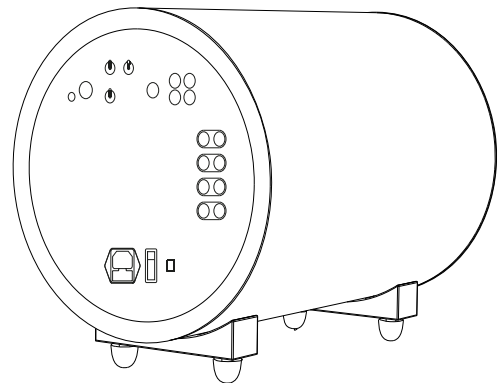

TR-3D BACK

ABOUT YOUR SUBWOOFER

Your TR-3D subwoofer uses many proprietary technologies to ensure the absolute best performance can be delivered. These contribute to an enhanced level of bass output, precision bass reproduction and dynamic range not found in other subwoofers of similar price and size.

Gallo Acoustics' S2 technology is a simple yet powerful approach to enhance low frequency extension, whilst neutralising internal resonance. This results in the woofer behaving as if it were in a larger enclosure, allowing deeper and more powerful bass than it ordinarily would produce. This technology can also be found in all Gallo Acoustics loudspeakers, and is precisely the innovation that allows Gallo Acoustics loudspeakers to deliver surprisingly full-range sound from compact enclosures.

For more information on Gallo Acoustics' design and technologies, please visit www.galloacoustics.com

PLACEMENT

The placement of your TR-3D subwoofer within the room is not as critical as speaker placement, since frequencies of 80Hz and below are non-directional. However, there are several things you can do to help you achieve the best performance from your subwoofer.

- Ensure that the PHASE control is used properly. As a general rule, if the subwoofer is in front of the listening position have the PHASE control at 0°. If the subwoofer is behind the listening position, then set the PHASE to 180°.
- The best performance is usually achieved by placing the subwoofer between your front speakers, facing the listening position.
- Placing near a rear wall will aid the bass response, however avoid corner positioning if possible as this will result in uneven bass response throughout the room.
- Disconnecting your loudspeakers so you are only listening to bass playback will help as you try to find areas of the room where bass is overpowering, or where bass is lacking.

Another tactic would be to select several positions that will suit the aesthetics of the room, and try each position in turn to see which position provides the best response. This settings of the subwoofer can then be tailored to suit the position.

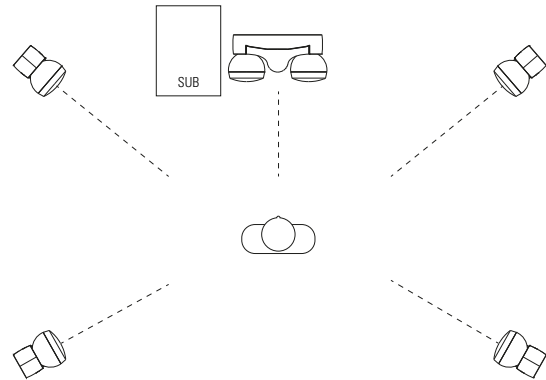
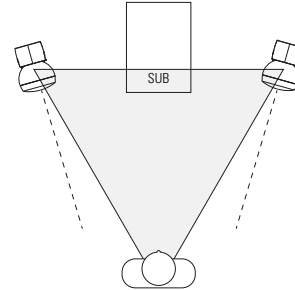

CONTROLS AND CONNECTIONS

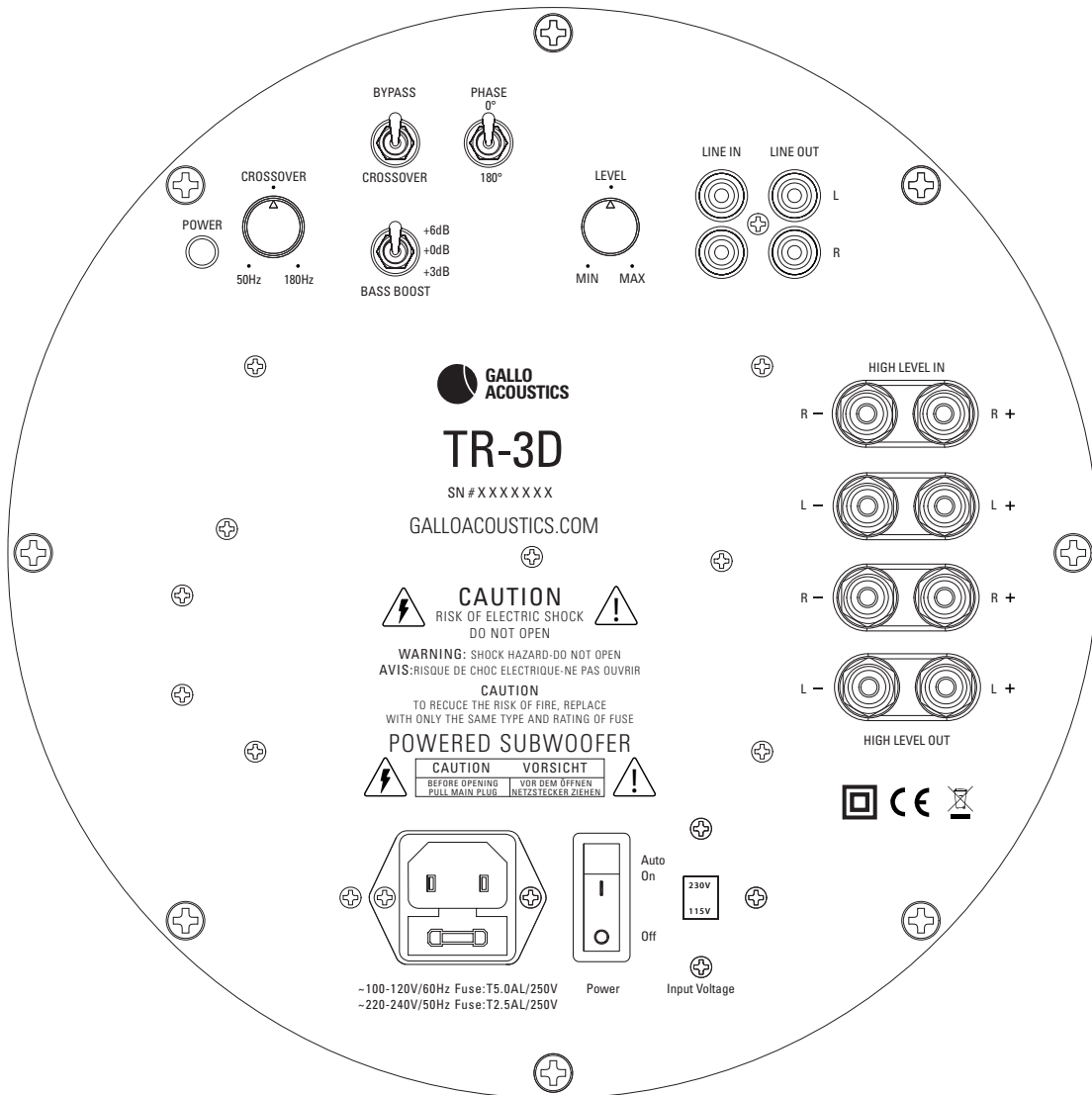

CONTROLS

CROSSOVER

The CROSSOVER control is variable from 50Hz to 180Hz. In simple terms, the subwoofer will play all frequencies below the CROSSOVER setting.

LEVEL

The LEVEL control sets the volume of the subwoofer in relation to the main speakers. Once set, volume will climb and decrease along with your main system volume.

PHASE

The PHASE control allows you to adjust the phase of the subwoofer relative to the main speakers. This helps when positioning the subwoofer - in general, if the subwoofer is in front of the listening position have the PHASE set to 0°. If the subwoofer is behind the listening position, then set the PHASE to 180°.

BYPASS/CROSSOVER

Activates the subwoofers built-in bass management, or bypasses it. If your amplifier has bass control, like an AV receiver, then set to BYPASS, otherwise set to CROSSOVER.

BASS BOOST

Allows for more convenient bass equalisation, increases bass volume in relation to the main speakers without adjusting any other controls.

POWER SWITCH

Set to either OFF, or AUTO ON. When set to AUTO ON, the TR-3D will automatically detect a signal from the source amplifier and, in turn, will power up the subwoofer. It will also return to its standby mode automatically when the source is no longer detected.

AC SELECTOR

This should be preset to your country of use. However you can adjust this if you move to a country where a different AC voltage is used. Note that you will also have to change the internal fuse to suit the AC voltage.

CONNECTIONS

HIGH LEVEL IN/OUT

The HIGH LEVEL IN is used to connect your amplifier to your subwoofer using speaker cables. You can then connect a pair of speaker to the HIGH LEVEL OUT. This will also activate the subwoofers built-in crossover, and protect the speakers from the lowest frequencies.

LINE IN/OUT

This is used to connect your TR-3D to your amplifier using a coaxial (RCA) cable. Connect the pre-out or LFE (SUBWOOFER) output on your amplifier to the LINE IN on the subwoofer. If required, you can connect the LINE OUT to your power amplifier.

POWER CONNECTOR

Plug the AC power cable here, and then into a mains supply, do this after all other connections have been made. Ensure that the AC SELECTOR is preset to the correct position for your country.

FUSE

The fuse protects the TR-3D subwoofer from abnormal power conditions. It's located under a small cover in the subwoofer AC power socket. If the subwoofer fails to power, check this fuse and only replace with the types noted below :

115V AC Supply - T5A 250V fuse

230V AC Supply - T2.5A 250V fuse

2.1 SET UP

There are two options for connecting the subwoofer in a 2.1 system - either using the HIGH LEVEL IN or the LINE IN. The style of speakers and amplifier you are using will dictate which method of connection you will use.

When using Gallo Acoustics Micro or A'Diva speakers, or similar compact loudspeakers, use the following method. This will run the subwoofer and protect your speakers from the lowest frequencies - ensure your subwoofer is set to CROSSOVER mode.

- Using speaker cables, connect the speaker outputs on your stereo amplifier to the HIGH LEVEL IN on the subwoofer.
- Run a second set of speaker cables from the HIGH LEVEL OUT on the subwoofer to your loudspeakers.
- Adjust the subwoofer's CROSSOVER to around 100Hz.
- When music is playing, you can adjust the LEVEL control to match the subwoofer and loudspeaker volume.

If your speakers can handle a full range signal, like our Strada 2 speakers, then you may wish to connect the subwoofer as follows. Ensure the subwoofer is set to CROSSOVER mode.

- Run speaker cables from your amplifier to your loudspeakers.
- If your amplifier has a pre-out, then this can be used to connect your amplifier to the subwoofer using a coaxial (RCA) cable.
- If there is no pre-out, then you can run a second set of speaker cables from your amplifier to the HIGH LEVEL IN of your subwoofer.
- On the subwoofer adjust the CROSSOVER to around 100Hz, once the system is playing music, you can adjust this to suit your loudspeakers performance capabilities.
- When music is playing, you can adjust the LEVEL control to match the subwoofer and loudspeaker volume.

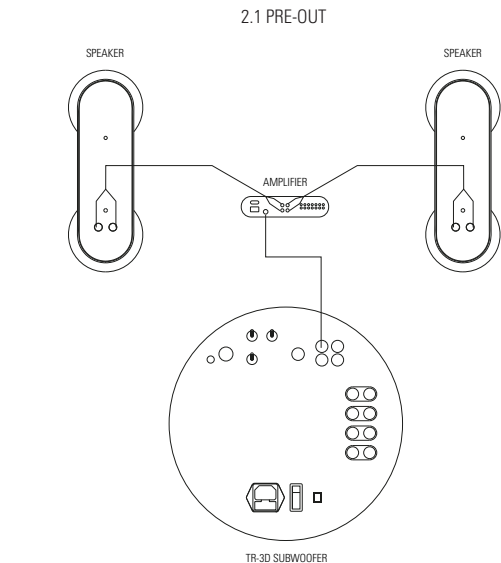
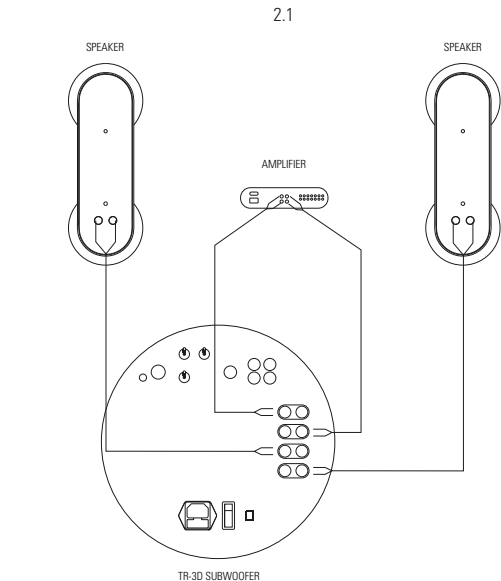

MULTI-CHANNEL SET UP

When using a multi-channel surround sound system, first ensure that you are familiar with your amplifier's functions to ensure that the correct mode and settings are applied.

- Identify your AV amplifier's SUBWOOFER or LFE output. Connect this to the left LINE IN on the subwoofer using an coaxial (RCA) cable.

Please note - You can use a Y-splitter to split the signal into both left and right LINE IN on the subwoofer. Alternatively, some amplifiers have two LFE (SUBWOOFER) outputs, which allows direct connection to both LINE IN connectors on the subwoofer via a twin coaxial (RCA) cable.

- Make adjustments on your AV amplifier to ensure that the correct frequency range is being distributed to your satellite speakers and subwoofer.

For Gallo Acoustics Micro and A'Diva loudspeakers, use a small speaker setting on your amplifier, to protect the loudspeakers from the lowest frequencies.

- Switch the subwoofer into BYPASS mode, as the AV amplifier will handle bass control and distribute the frequencies accordingly.
- When music or a film is playing, adjust the LEVEL control so the subwoofer volume matches the satellite speaker volume.

Consult both your AV Amplifier and loudspeaker owner's guides for more detailed set up instructions of these components.

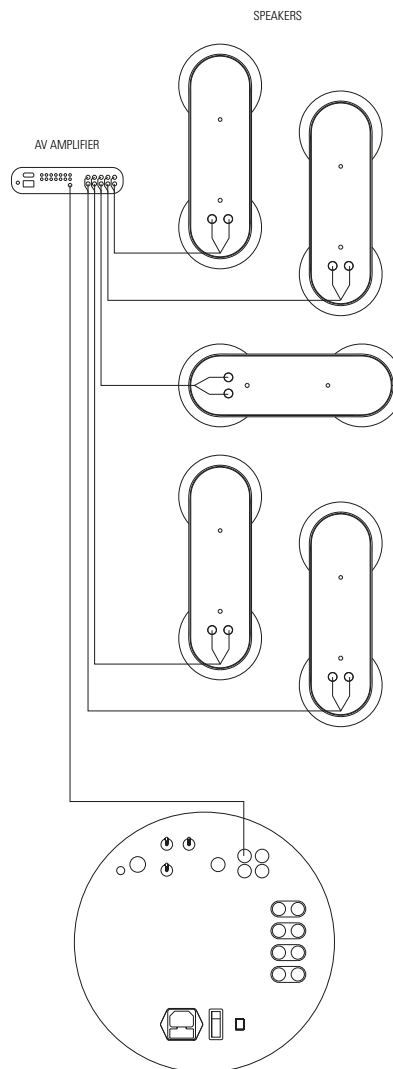

SPECIFICATIONS

Frequency Response	18Hz to 180kHz +/- 3db
Class D Digital Power Amp	300 watts RMS
Active low pass filter	50Hz to 180Hz, continually variable, with bypass
High Pass Filter	100Hz on High Level Output
Woofer	10" long throw, ceramic coated aluminium
Dimensions	W - 27.5cm (10.75") H - 30.5cm (12") D - 34.5cm (13.5")
Weight	12.7Kg
Enclosure Material	Hardened steel
Warranty	2 years

WARNING

Care must be taken positioning the subwoofer to ensure that it won't be damaged or knocked over.

If you are in any way unsure of the correct installation or use then please consult qualified sources before taking unnecessary risks.

The manufacturer, distributor or their agents cannot be held responsible for any injury as a result of improper use or installation of this product.

TECHNICAL SUPPORT

Should you encounter problems using this product, please contact your dealer or local distributor.

You can call Gallo Acoustics directly for technical support on the following numbers:

UK
01555 666883

Outside UK
+44 1555 666883

United States, Canada and South America
866 427 3873

Alternatively, email -
support@galloacoustics.com

WARRANTY

Anthony Gallo Acoustics Ltd warrants to the end user that this product will be free from defects in materials and workmanship in the course of normal use for a period of five years from the date of purchase.

This guarantee covers breakdowns due to manufacturing faults and does not apply in cases such as accidental damage, general wear and tear, user negligence, modification or repair not by Anthony Gallo Acoustics Ltd.

To register your purchase please visit -
www.galloacoustics.com





ANTHONY GALLO ACOUSTICS LTD
THE INOX BUILDING
CALDWELLSIDE
LANARK
SCOTLAND
UNITED KINGDOM
ML11 7SR

WWW.GALLOACOUSTICS.COM
